

How does the rotation of the TTMA-100 affect its safety performance?

The TTMA-100's ability to rotate represents a major improvement in TMA safety technology. While competing trailer attenuators utilize rotational restraints to prevent the attenuator from rotating, the TTMA-100 allows the trailer to rotate in order to keep the system aligned with the impacting vehicle to maximize energy dissipation. It is this innovative approach to energy management that has allowed the TTMA-100 to become the only TMA system to successfully pass NCHRP Report 350 optional offset and angled tests when attached to a support truck blocked against forward motion.

The primary concern about allowing a trailer to rotate is that the impacting vehicle would push the trailer out of its path and directly strike the rear of the support truck. However, as shown in the Figure 1, an impacting vehicle must slide along the trailer's impact face in order to disengage from the trailer.

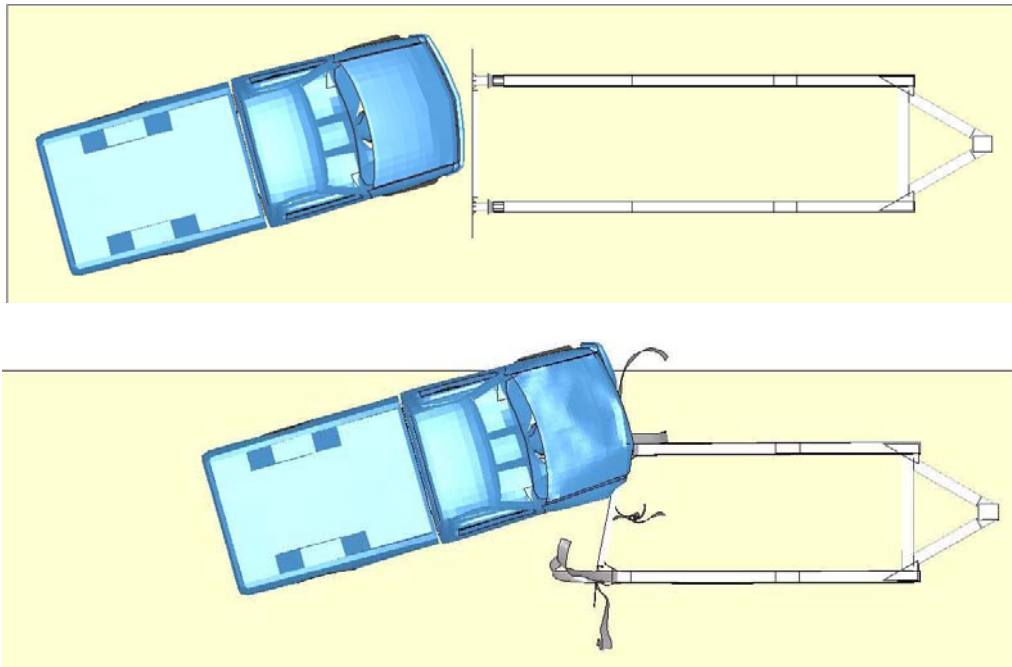

Figure 1. Simulation of Vehicle Disengaging from a Trailer.

The patented innovation that eliminates this risk is the way the TTMA-100 engages an impacting vehicle. The TTMA-100's impact plate is designed to capture the front of a vehicle and lock the trailer between the impacting vehicle and the tow vehicle. The TTMA-100's impact head, shown in Figure 2, utilizes vertical steel angles to prevent impacting vehicles from sliding horizontally along the face of the trailer. The impact head also utilizes steel channels with the legs oriented toward traffic to prevent vertical motion on the front of an impacting vehicle to eliminate the risk of diving under or riding over the attenuator.



Figure 2. TTMA-100 Impact Head.

The effectiveness of this mechanical interlock system can be illustrated by comparing final rest locations from NCHRP Report 350 pickup truck offset and angled tests (tests 3-52 and 3-53, respectively) for the three trailer TMA systems that have received FHWA approval. Note that only the TTMA-100 was tested under the much more stringent conditions of blocking the support truck against any forward motion. The other two trailer TMA systems were tested with 20,000-lb support trucks which were allowed to roll ahead during the crash. Figure 3, shown below, was developed from FHWA approval letters and shows the final rest locations of the three trailer TMA systems for the optional offset and angled tests recommended by NCHRP 350. This figure clearly shows that the final rest locations for the three designs are not substantially different, even though the TTMA-100 was tested under the more severe condition with the support truck blocked against forward movement. Figure 3 clearly demonstrates that the TTMA-100's simple pintle hook attachment and its vehicle capturing impact head are able to perform very well during offset and angled impacts, even when attached to an infinitely heavy support truck.

In fact, the combination of the simple pintle hook attachment and the trailer's connection with the support vehicle, forces the trailer to rotate and align itself with the impacting force, which would in turn maximize energy dissipation. **Hence, the TTMA-100 provides maximum energy dissipation for impacts at any angle to provide maximum safety to both motorists and construction workers.**

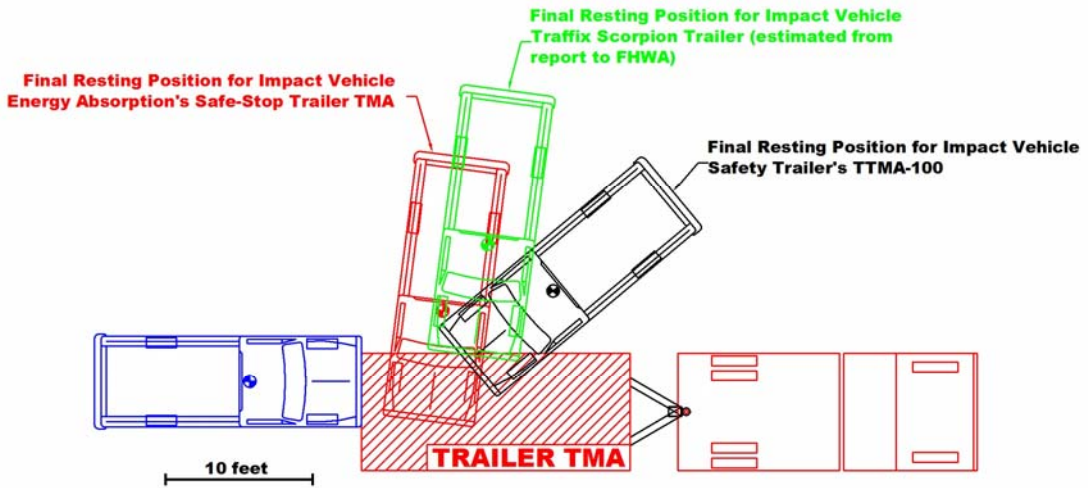

NCHRP Report 350 Optional Test 3-52

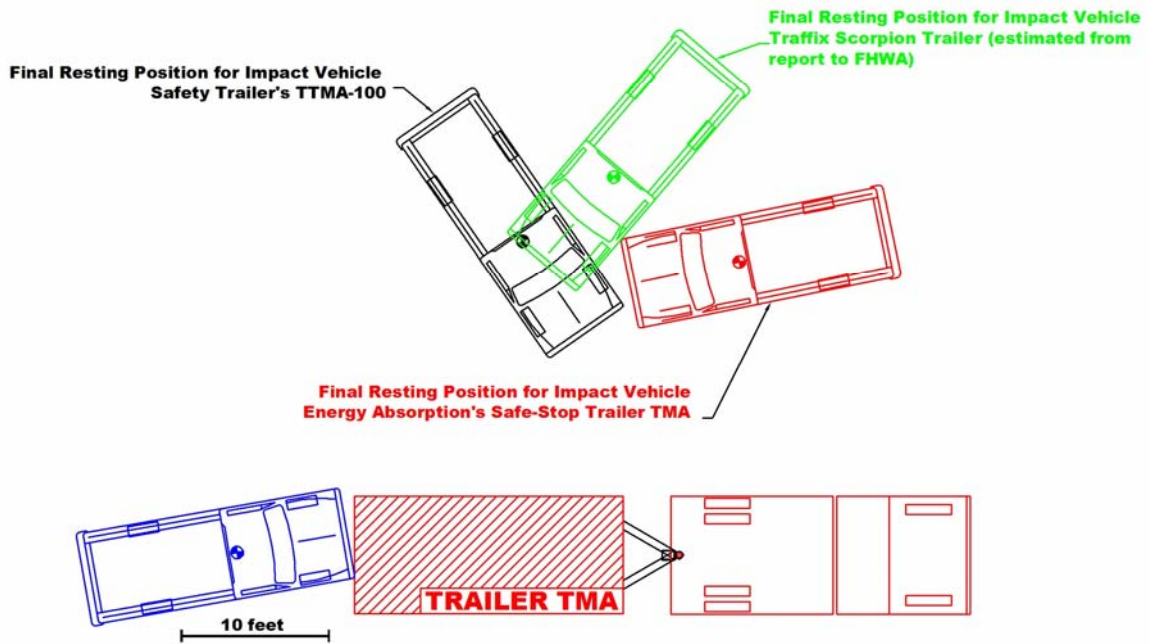

NCHRP Report 350 Optional Test 3-53